

THIS DRAWING IS UNPUBLISHED. RELEASED FOR PUBLICATION, 19 .
 © COPYRIGHT 19 BY AMP INCORPORATED. ALL INTERNATIONAL RIGHTS RESERVED.

LOC	DIST	P	F	REVISIONS		DATE	APPD
G	14			ZONE	LTR	DESCRIPTION	
				H		REL PER 063A-0372-02	JR/MS

METRIC
 DIMENSIONS LISTED IN mm [INCHES]

AMP WIRE RANGE	UL E13288 Listed
14-12 AWG SOLID OR STRANDED	14-12 AWG STRANDED
SP LR7189 Certified	MILITARY P/N AND CLASS
14-12 AWG SOLID OR STRANDED	NOT APPLICABLE

- ① STAMP AMP 14-12* APPROX AS SHOWN
- ② MAXIMUM LENGTH DOES NOT INCLUDE MANUFACTURING TABS

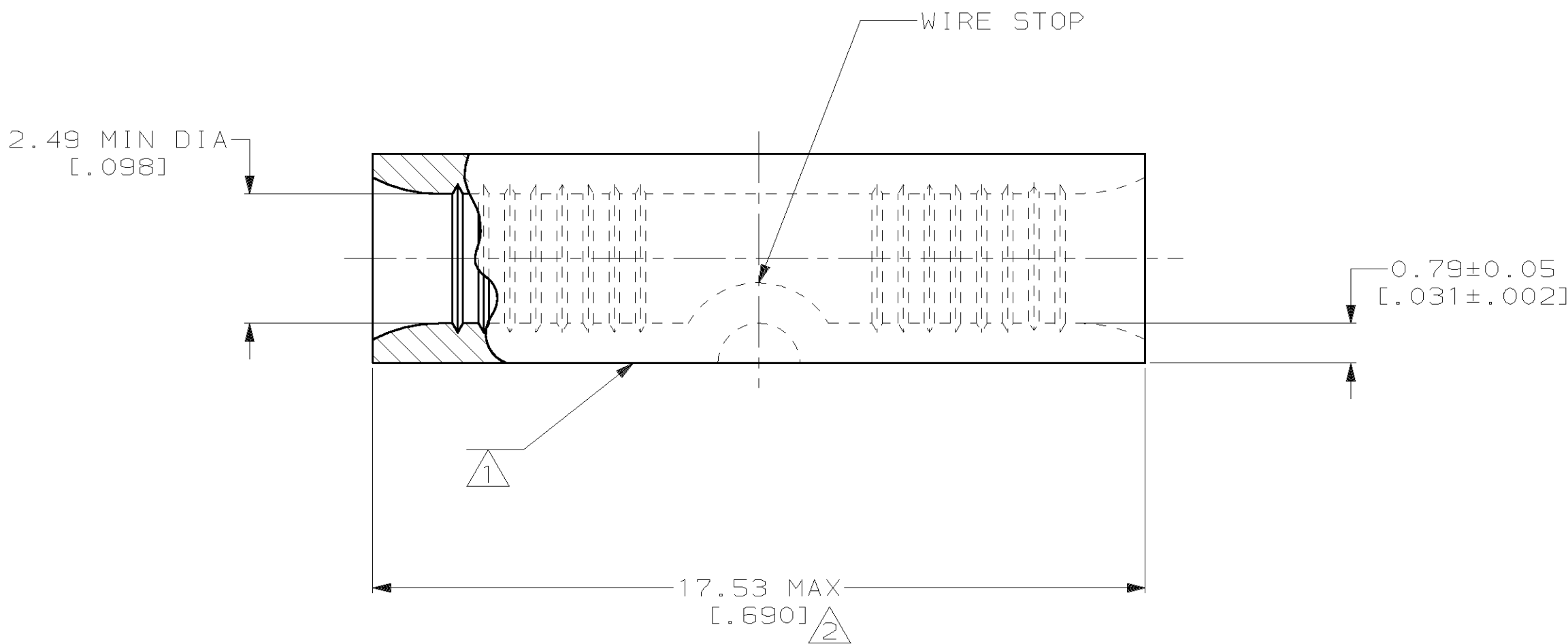
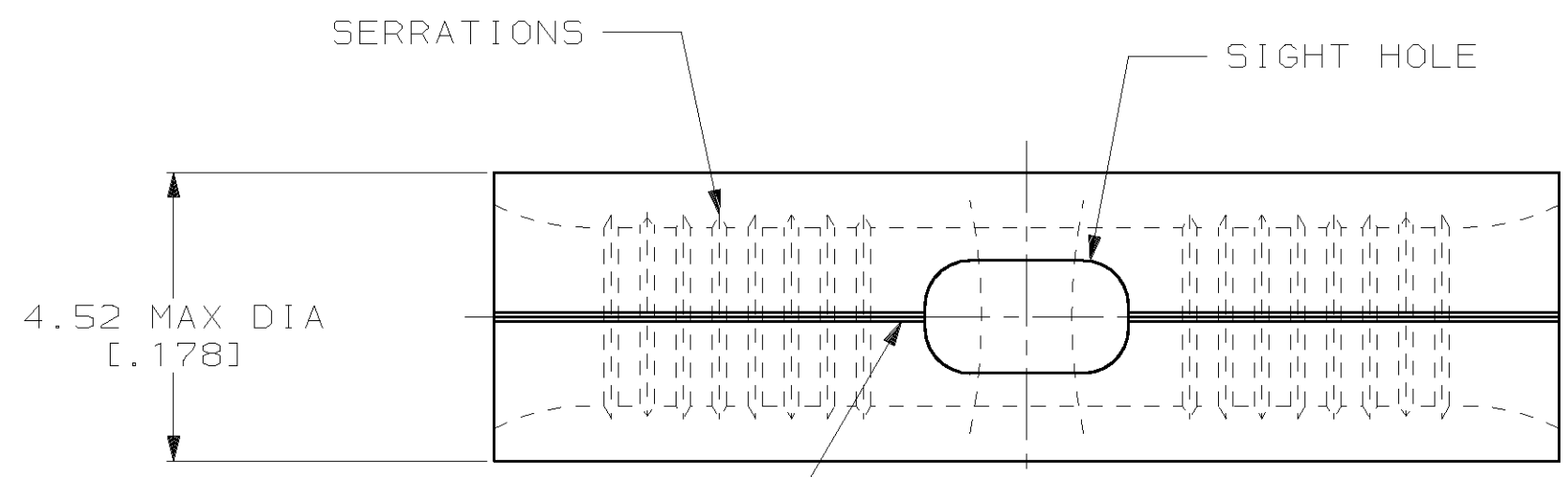

5000	ON TAPE, REEL	1-321280-1
-	LOOSE PIECE	321280
QTY	PACKAGE TYPE	PART NO

AMP INCORPORATED
CUSTOMER SERVICE SYSTEMS

MAX RECOMMENDED OPERATING TEMPERATURE:
 170°C MAX

DO NOT SCALE PRINT. UNLESS SPECIFIED
 DIMENSIONS IN mm [INCHES]
 TOLERANCES ON:
 2 PLC DEC ± -
 3 PLC DEC ± -
 ANGLES ± -

DR 4-13-93
 TA BRINKMAN
 CHK 4-13-93
 DA PATTERSON
 APPD 4-13-93
 DE MILLER
 APPD 4-13-93
 JL MECKLEY

AMP AMP Incorporated
 Harrisburg, PA 17105-3608

FOR ADDITIONAL PRODUCT INFORMATION OR COPIES OF DRAWINGS AND TECHNICAL DOCUMENTS

PRODUCT INFORMATION CENTER
 1-800-522-6752

VOLTAGE RATING:
 NOT APPLICABLE

MATERIAL
 COPPER PER ASTM B-152 ANNEALED

PRODUCT SPEC
 -

NAME
 SPLICE, BUTT, SIGHT HOLE, SOLISTRAND

FOR APPLICATION TOOLING INFORMATION

TOOLING ASSISTANCE CENTER
 1-800-722-1111

WIRE CROSS SECTIONAL AREA RANGE:
 1.65-4.17mm² [3,260-8,230] CIR MILS
 SOLID OR STRANDED

FINISH
 TIN PLATE
 0.00254[0.000100] MIN PER ASTM B-545

APPLICATION SPEC
 -

SIZE CAGE CODE DRAWING NO
 C 00779 C=321280

FOR ORDER ENTRY

1-800-526-5142

THIS DRAWING IS A CONTROLLED DOCUMENT FOR AMP INCORPORATED. IT IS SUBJECT TO CHANGE AND THE CONTROLLING ENGINEERING ORGANIZATION SHOULD BE CONTACTED FOR THE LATEST REVISION.

WEIGHT -

SCALE 10:1 SHEET 1 OF 1